



Injector puller set K 439



SAFETY AND PRECAUTION

- 1 Always follow instructions provided by the vehicle manufacturer regarding handling and safety measures.



- 1 Puller sleeve
- 2 Puller spindle with shoulder nut
- 3 Injector nozzle socket, 29 mm
- 4 Hex bit socket, 10 mm

PRODUCT SPECIFICATIONS

For removing injectors on for example Mercedes-Benz Sprinter, ML 270, E-class, C-class, Grand Cherokee 2,7 from 2000.

OPERATION INSTRUCTIONS

- 1 Remove fuel lines and wire connections.
Using the 29 mm socket (3), remove the nozzle head.
Also remove the injector clamp.
- 2 Using the 10 mm hex bit socket (4), remove the threaded plug.
- 3 Attach the puller spindle (2) to the injector body.
- 4 Place the puller sleeve (1) over the injector body and attach the shoulder nut on the spindle.
- 5 Hold the spindle with a wrench, while turning the shoulder nut clockwise to pull out the injector body. Note, do not use an impact wrench for this operation.

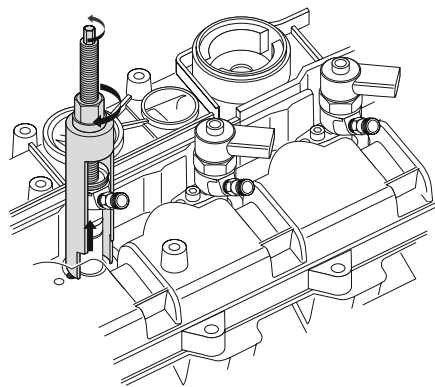
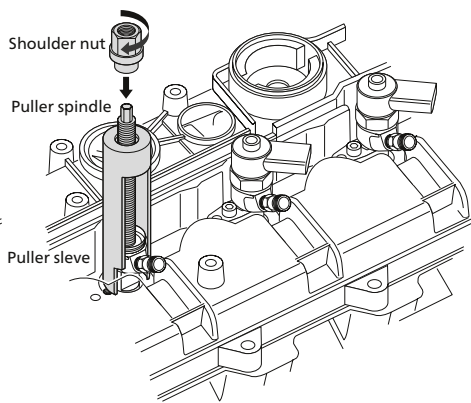
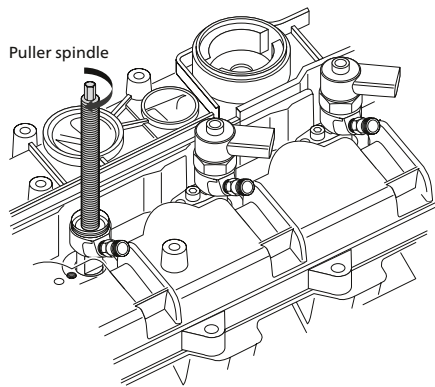
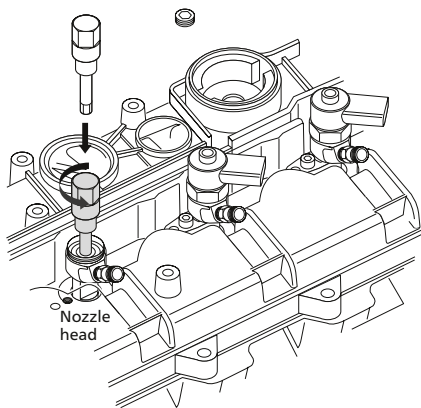
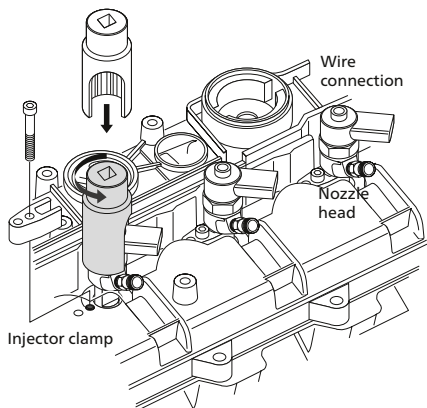

PARTS LIST

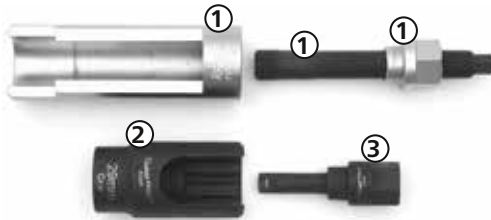

Pos.	Stock No.	Description
1	KR 439 1	Puller sleeve, puller spindel and shoulder nut
2	K 433	Injector nozzle socket, 29 mm
3	KR 439 2	Hex bit socket, 10 mm

K 439

www.kamasatools.com